

REV	DESCRIPTION	BY	DATE	EON
A	ENGINEERING RELEASE	PED	11-2-95 MP	M14366

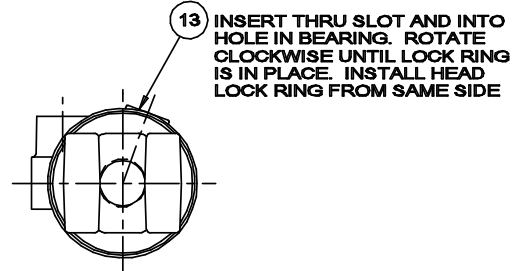
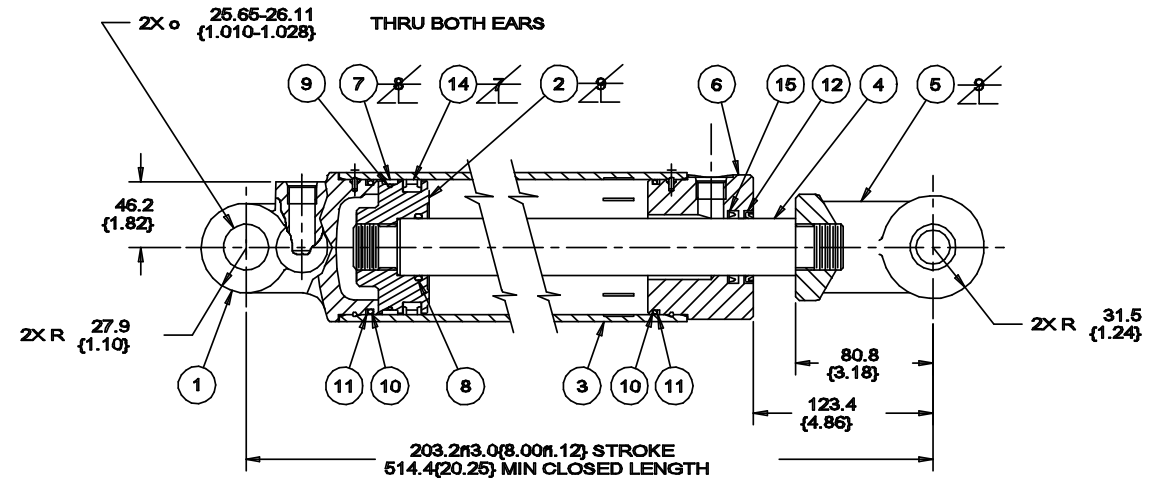
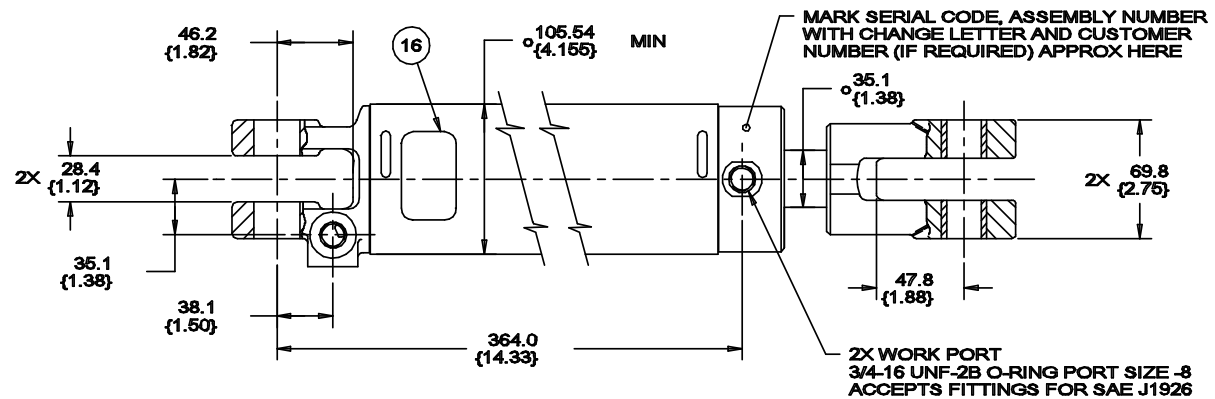

- NOTE
- 1 TEST PER SPEC 209-207
  - 2 RATED PRESSURE IS 172.4 bar (2500 lbf/in<sup>2</sup>)
  - 3 PAINT RED PER SPEC 209-13C
  - 4 CUSTOMER NAME - BOURGAULT
  - 5 CUSTOMER NUMBER - 3301-33
  - 6 SEAL REPAIR KIT NUMBER - 58360-905
  - 7 BACK UP WASHERS TO BE INSTALLED WITH CHAMFER FACING TOWARDS SEAL
  - 8 GAP IN WEAR RING TO BE INSTALLED 90° TO PIN HOLE IN ROD END AND TOWARDS LOCK RING SLOT IN BARREL
  - 9 TORQUE TO 353-380 N.m (260-280 lbf.ft)

-	SHPNG PLUG (NOT SHOWN)	16096-108	2
16	LABEL	58025-17	1
15	ROD SEAL	16184-125	1
14	PISTON SEAL	58023-6	1
13	LOCK RING	16098-123	2
12	WIPE SEAL	16074-222	1
11	BACK-UP WASHER	16012-216	2
10	O-RING	16004-16	2
9	O-RING	16015-49-90	1
8	O-RING	16003-25-90	1
7	WEAR RING	16283-130	1
6	BEARING	58009-364	1
5	ROD END	58030-1301	1
4	PISTON ROD	58006-1301	1
3	BARREL	58004-3608	1
2	PISTON	58022-6	1
1	HEAD	58001-360	1

ITEM NO.	PART NAME	PART NO.	NO. REQ'D
----------	-----------	----------	-----------

### BOURGAULT PART # 3301-33

UNLESS OTHERWISE SPECIFIED, ALL DIMENSIONS ARE IN MILLIMETERS (INCHES) DECIMALS <input type="checkbox"/> FRACTIONS <input checked="" type="checkbox"/>	DRAWING BASED ON ANSI Y14.5M-1982		
	NOTICE TO PERSONS RECEIVING THIS DRAWING AND/OR TECHNICAL INFORMATION Eaton Corporation retains proprietary rights in the information disclosed herein. This document is loaned to you in confidence and is not to be reproduced or used to manufacture anything other than those items without the written permission of the Eaton Corporation.		
TOLERANCES	DIMENSION SYSTEM: PED 11-2-95 UNITS: MP 11-14-95 DIMENSION SYSTEM: JEK 11-14-95	DIMENSIONAL TOLERANCES: NOTED TITLE: $\phi$ 95.2 (3.75) WYR LOC CYL ASSY	PART NO: 58364-MAB QUANTITY: NONE UNIT: 1 of 1
UNLESS OTHERWISE SPECIFIED, ALL DIMENSIONS ARE IN MILLIMETERS (INCHES) DECIMALS <input type="checkbox"/> FRACTIONS <input checked="" type="checkbox"/>	DIMENSIONAL TOLERANCES: NOTED TITLE: $\phi$ 95.2 (3.75) WYR LOC CYL ASSY	PART NO: 58364-MAB QUANTITY: NONE UNIT: 1 of 1	